

BF)Techno

TZ-1000 SERIES



BF Techno GmbH
Munzer Technology

DIMENSIONS

TZ SERIES

TZ-1000 SERIES

MODEL

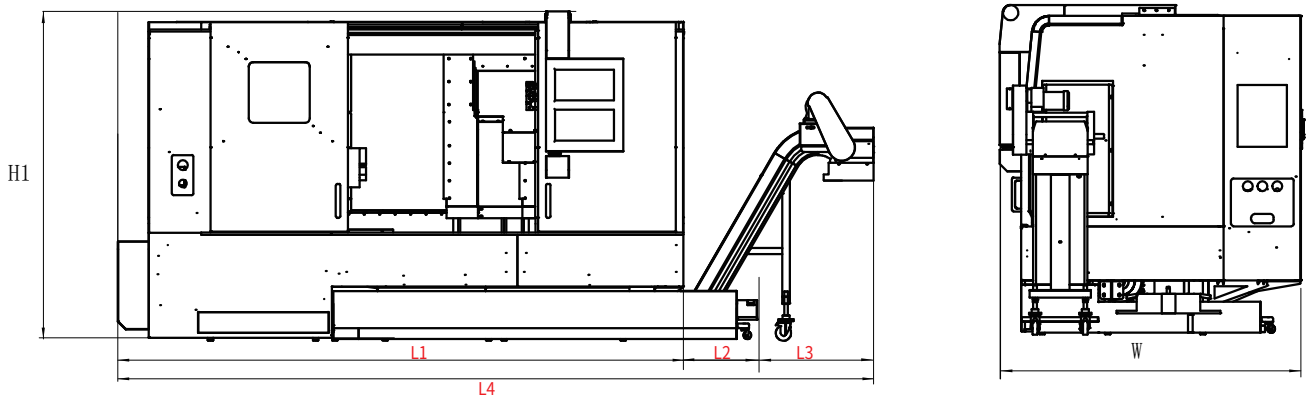

	TZ-1000	TZ-1000M	TZ-1000MY	TZ-1000MYW
L1	3730	3730	3730	3730
L2	650	650	650	650
L3	670	670	670	670
L4	5050	5050	5050	5050
W	2110	2110	2110	2110
H1	2095	2095	2225	2225

TECHNICAL SPECIFICATIONS

TZ SERIES

TZ-1000 SERIES

CONTENT		unit	TZ-1000	TZ-1000M	TZ-1000MY	TZ-1000MYW
Capacity	Max. swing over bed	mm	Φ580	Φ580	Φ650	Φ650
	Max. turning diameter	mm	Φ470	Φ400	Φ400	Φ400
	Max. turning length	mm	980	920	930	900
	Bar hole	mm	Φ75	Φ75	Φ75	Φ75
Spindle	Spindle nose	-	A2-8	A2-8	A2-8	A2-8
	Spindle hole	mm	Φ87	Φ87	Φ87	Φ87
	Spindle speed	rpm	2500	2500	2500	2500
	Spindle motor	kw	15/18.5	15/18.5	15/18.5	15/18.5
	Chuck size	inch	10 "	10 "	10"	10"
Sub Spindle	Spindle nose	-	/	/	/	A2-5
	Spindle hole	mm	/	/	/	Φ56
	Bar hole	mm	/	/	/	Φ45
	Spindle speed	rpm	/	/	/	5500
	Spindle motor	kw	/	/	/	13.8
	Chuck size	inch	/	/	/	6"
Axis travel	x/z/y axis travel	mm	260/980	260/920	260/930/±50	255/900/±50
	x/z/y axis motor	kw	3.0/3.0	3.0/3.0	3.0/3.0/1.4	3.0/3.0/1.4
	x/z/y axis rapid traverse	m/min	24/24	24/24	24/24/6	24/24/6
	positioning accuracy	mm	±0.005	±0.005	±0.005	±0.005
	repeat accuracy	mm	±0.003	±0.003	±0.003	±0.003
Tool Turret	Tool Turret type	-	Servo Turret-12T	BMT55-12T	BMT55-12T	BMT55-12T
	O.D. tool holder	mm	25*25	25*25	25*25	25*25
	I.D. tool holder	mm	Φ40	Φ40	Φ40	Φ40
Tailstock	Tailstock type	-	Programmable hydraulic tailstock (Optional servo tailstock)			/
	Taper	-	MT#5	MT#5	MT#5	/
	Quill diameter	mm	Φ80	Φ80	Φ80	/
	Quill travel	mm	80	80	80	/
Machine dimensions	L*W*H (include chip conveyor)	mm	5050*2110*2095	5050*2110*2095	5050*2110*2225	5050*2110*2225
	w eight	kg	5300	5400	5600	5800