

BF Techno

TZ-500 SERIES



BF Techno GmbH
Munzer Technology

DIMENSIONS

TZ SERIES

TZ-500 SERIES

MODEL

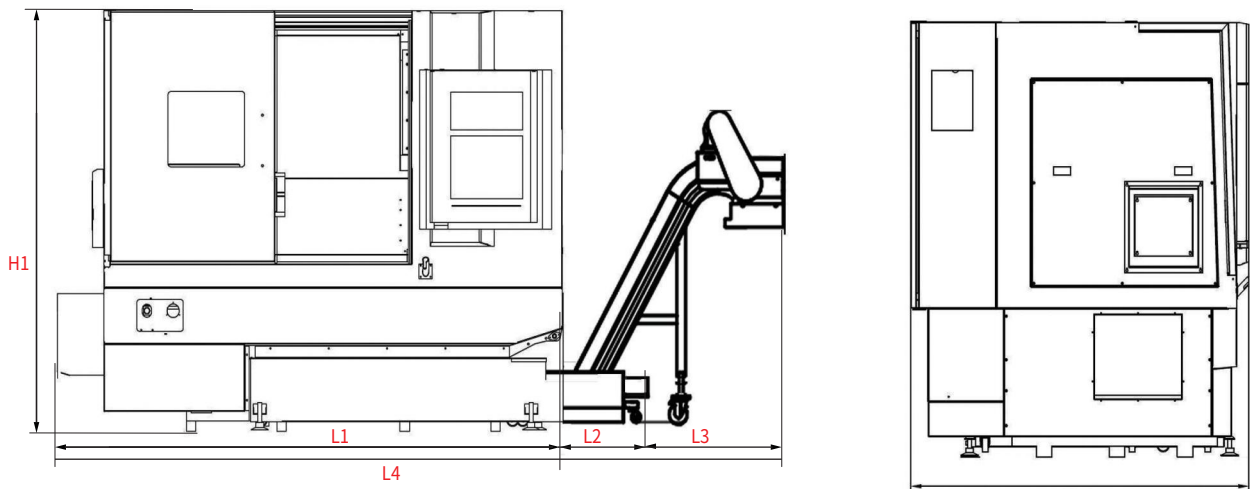

	TZ-500	TZ-500M	TZ-500MY	TZ-500MYW
L1:	2820	2820	2820	2820
L2:	630	630	630	630
L3:	730	730	730	730
L4:	4180	4180	4180	4180
W:	2010	2010	2010	2010
H1:	2040	2040	2170	2170

TRAVELS

TZ SERIES

TZ-500 SERIES

TZ-500

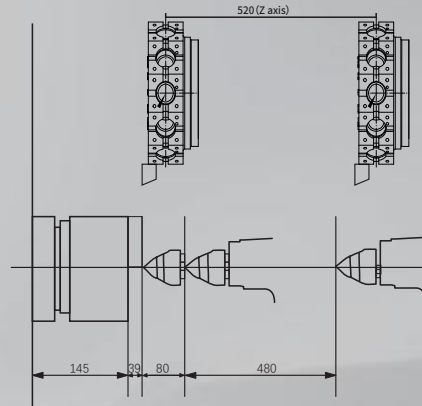
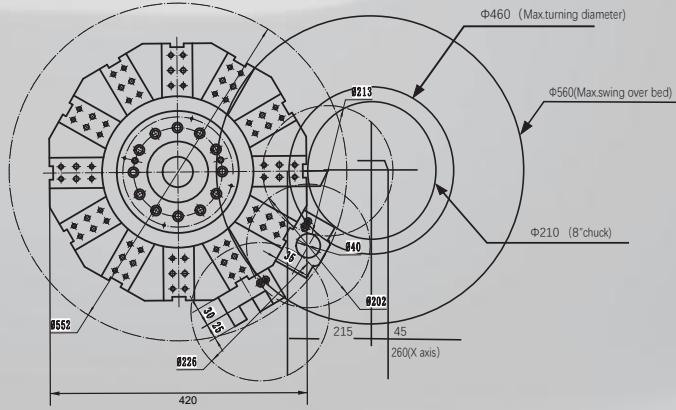

TZ-500M

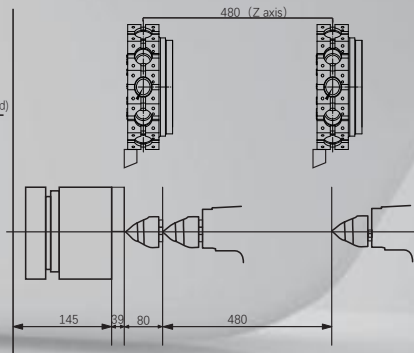
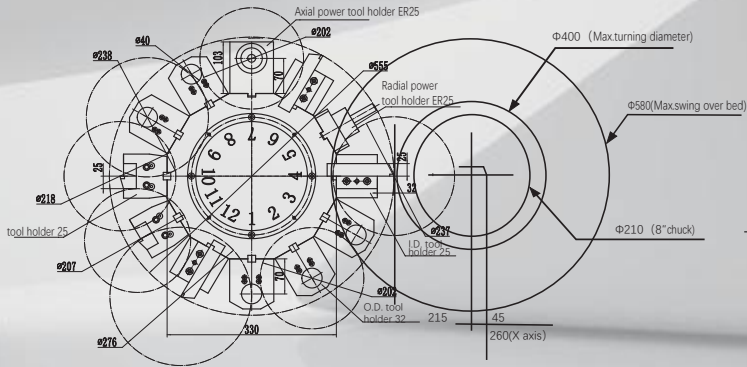

TZ-500MY

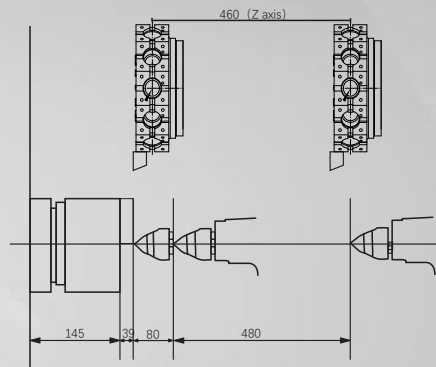
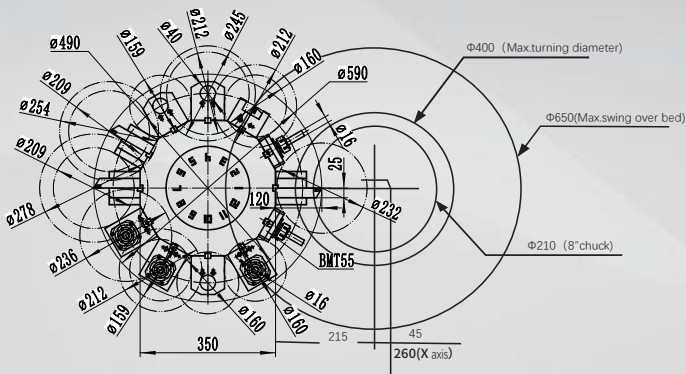

TZ-500MYW

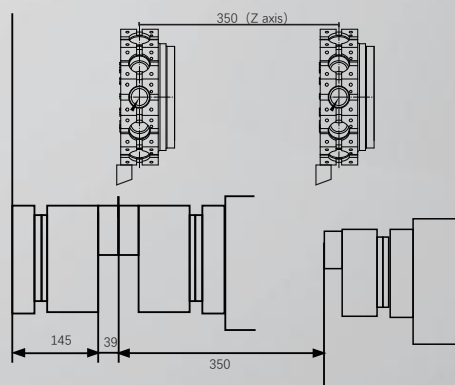
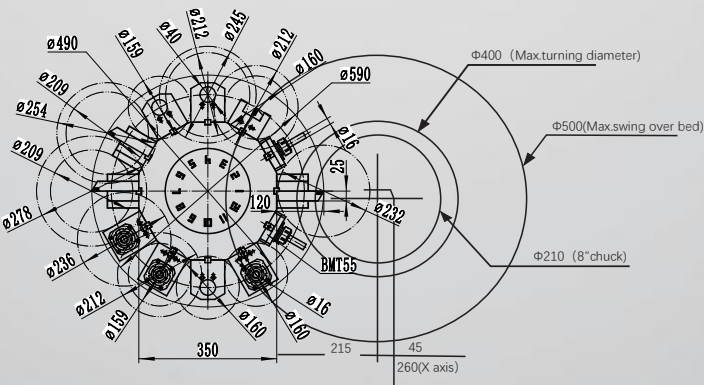

TECHNICAL SPECIFICATIONS

TZ SERIES

TZ-500 SERIES

CONTENT		unit	TZ-500	TZ-500M	TZ-500MY	TZ-500MYW
Capacity	Max. swing over bed	mm	Φ580	Φ580	Φ650	Φ650
	Max. turning diameter	mm	Φ460	Φ400	Φ400	Φ400
	Max. turning length	mm	520	480	460	350
	Bar hole	mm	Φ52	Φ52	Φ52	Φ52
Spindle	Spindle nose	-	A2-6	A2-6	A2-6	A2-6
	Spindle hole	mm	Φ65	Φ65	Φ65	Φ65
	Spindle speed	rpm	4200	4200	4200	4200
	Spindle motor	kw	11/15	11/15	11/15	11/15
	Chuck size	inch	8"	8"	8"	8"
Sub Spindle	Spindle nose	-	/	/	/	A2-5
	Spindle hole	mm	/	/	/	Φ45
	Bar hole	mm	/	/	/	Φ56
	Spindle speed	rpm	/	/	/	5500
	Spindle motor	kw	/	/	/	13.8
	Chuck size	inch	/	/	/	6"
Axis travel	x/z/y axis travel	mm	260/520	260/480	260/460±50	255/350±50
	x/z/y axis motor	kw	3.0/3.0	3.0/3.0	3.0/3.0/1.4	3.0/3.0/1.4
	x/z/y axis rapid traverse	m/min	24/24	24/24	24/24/6	24/24/6
	positioning accuracy	mm	±0.005	±0.005	±0.005	±0.005
	repeat accuracy	mm	±0.003	±0.003	±0.003	±0.003
Tool Turret	Tool Turret type	-	Servo Turret-12T	BMT55-12T	BMT55-12T	BMT55-12T
	O.D. tool holder	mm	25*25	25*25	25*25	25*25
	I.D. tool holder	mm	Φ40	Φ40	Φ40	Φ40
Tailstock	Tailstock type	-	Programmable hydraulic tailstock (Optional servo tailstock)			/
	Taper	-	MT#5	MT#5	MT#5	/
	Quill diameter	mm	Φ80	Φ80	Φ80	/
	Quill travel	mm	80	80	80	/
Machine dimensions	L*W*H (include chip conveyor)	mm	4180*2010*2040	4180*2010*2040	4180*2010*2170	4180*2010*2170
	weight	kg	4000	4200	4300	4500