

BF)Techno

TZ-750 SERIES



BF Techno GmbH
Munzer Technology

DIMENSIONS

TZ SERIES

TZ-750 SERIES

MODEL

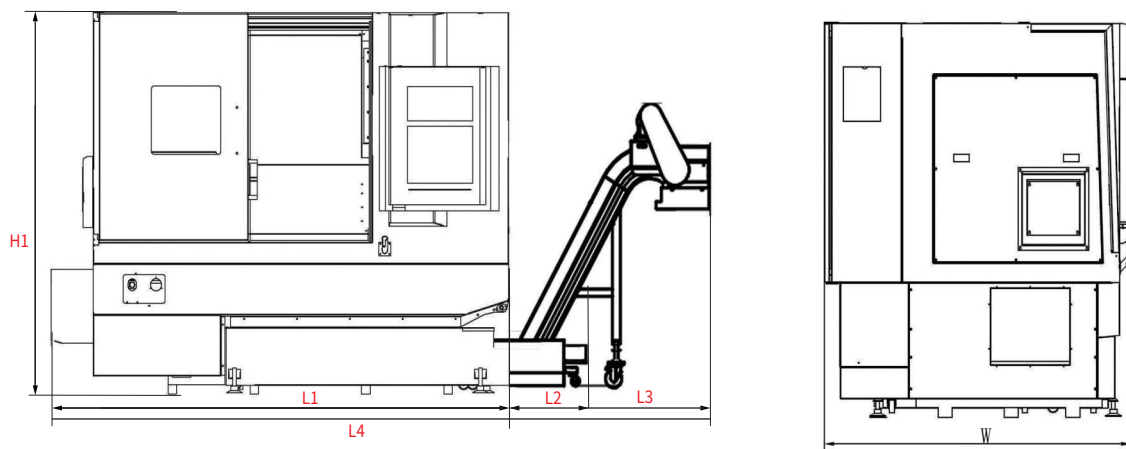

	TZ-750	TZ-750M	TZ-750MY	TZ-750MYW
L1	3140	3140	3140	3140
L2	630	630	630	630
L3	730	730	730	730
L4	4500	4500	4500	4500
W	2045	2045	2045	2045
H1	2095	2095	2225	2225

TRAVELS

TZ SERIES

TZ-750 SERIES

TZ-750

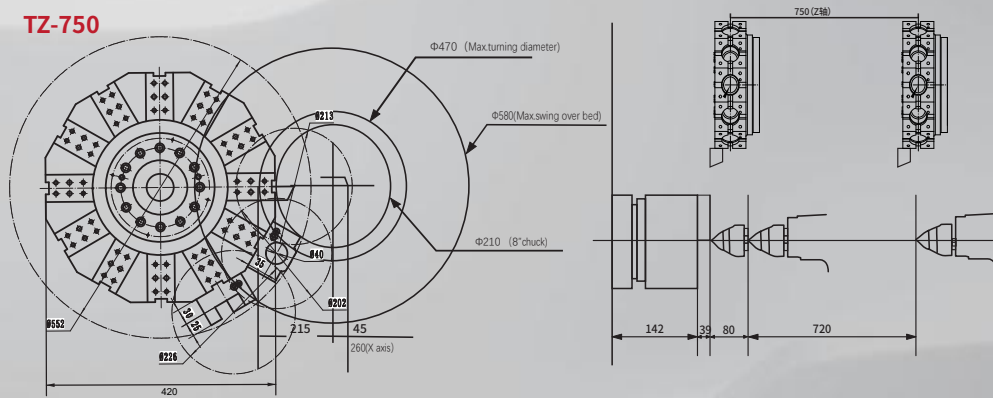

TZ-750M

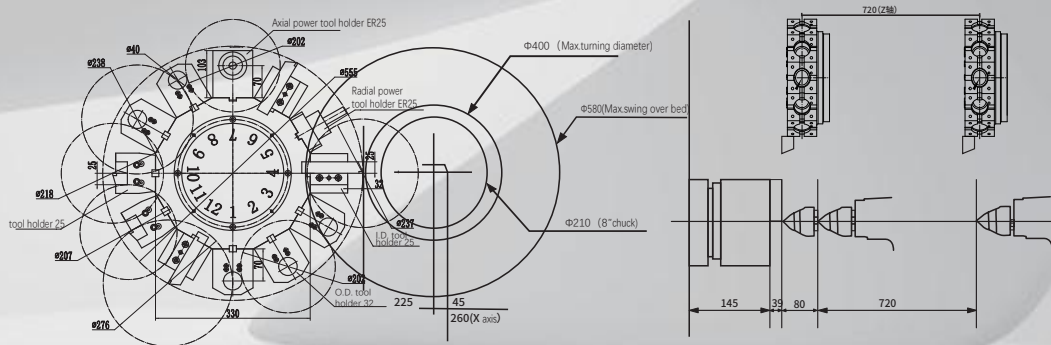

TZ-750MY

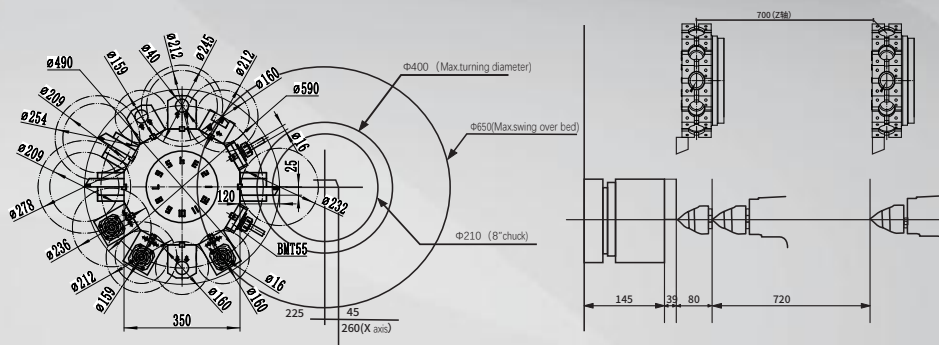

TZ-750MYW BMT55-12T

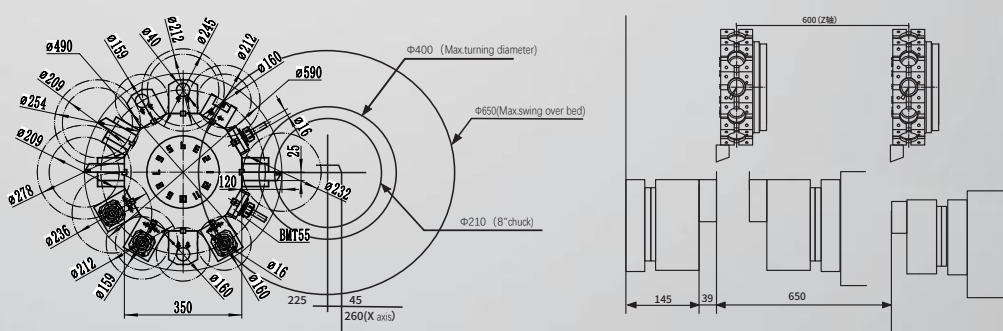

TECHNICAL SPECIFICATIONS

TZ SERIES

TZ-750 SERIES

CONTENT		unit	TZ-750	TZ-750M	TZ-750MY	TZ-750MYW
Capacity	Max. swing over bed	mm	Φ580	Φ670	Φ670	Φ700
	Max. turning diameter	mm	Φ470	Φ400	Φ400	Φ410
	Max. turning length	mm	750	680	700	600
	Bar hole	mm	Φ52	Φ52	Φ52	Φ52
Spindle	Spindle nose	-	A2-6	A2-6	A2-6	A2-6
	Spindle hole	mm	Φ65	Φ65	Φ65	Φ65
	Spindle speed	rpm	4200	4200	4300	4200
	Spindle motor	kw	11/15	11/15	11/15	11/15
	Chuck size	inch	8"	8"	8"	8"
Sub Spindle	Spindle nose	-	-	-	-	A2-5
	Spindle hole	-	-	-	-	Φ56
	Bar hole	-	-	-	-	Φ45
	Spindle speed	-	-	-	-	4200
	Spindle motor	-	-	-	-	11/15
	Chuck size	-	-	-	-	6"
Axis travel	x/z/y axis travel	mm	260/750	260/810	260/710/±50	260/650/±50
	x/z/y axis motor	kw	3.0/3.0	3.0/3.0	3.0/3.0/1.4	3.0/3.0/1.4
	x/z/y axis rapid traverse	m/min	24/24	24/24	24/24/6	24/24/6
	positioning accuracy	mm	±0.008	±0.008	±0.005	±0.005
	repeat accuracy	mm	±0.005	±0.005	±0.003	±0.003
Tool Turret	Tool Turret type	-	Servo Turret12T	Servo Turret12T	BMT55-12T	BMT55-12T
	O.D. tool holder	mm	25*25	25*25	25*25	25*25
	I.D. tool holder	mm	40	40	Φ40	Φ40
Tailstock	Tailstock type	-	Hydraulic program tailstock(optional servo tailstock)			/
	Taper	-	MT#5	MT#5	MT#5	/
	Quill diameter	mm	Φ80	Φ80	Φ80	/
	Quill travel	mm	80	80	80	/
Machine dimensions	L*W*H (include chip conveyor)	cm	4500*2045*2095	4500*2045*2095	4500*2045*2225	4500*2045*2225
	weight	kg	4500	4600	4700	4900