

BF Techno

TZ500 SERIES



BF Techno GmbH
Munzer Technology

DIMENSIONS

TZ SERIES

TZ500 SERIES

MODEL

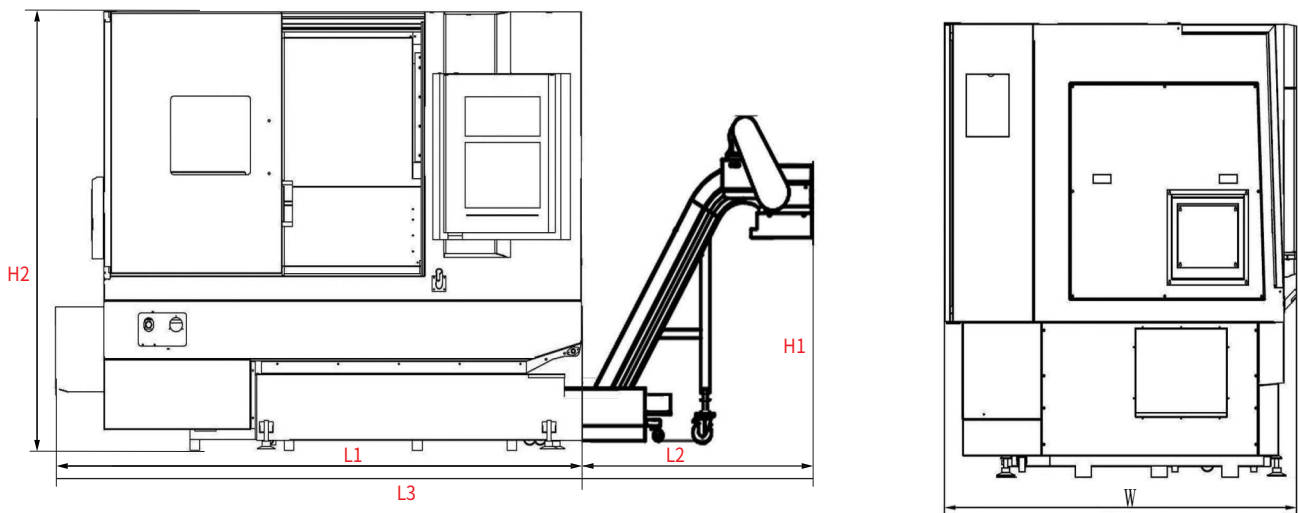

	TZ-500	TZ-500M	TZ-500MY	TZ-500MYW
L1:	2790	2790	2790	2790
L2:	1108	1108	1108	1108
L3:	3898	3898	3898	3898
W:	1730	1730	1730	1730
H1:	1625	1625	1625	1625
H2:	2020	2020	2170	2170

TECHNICAL SPECIFICATIONS

TZ SERIES

TZ500 SERIES

CONTENT		unit	TZ-500	TZ-500M	TZ-500MY	TZ-500MYW
Capacity	Max. swing over bed	mm	Φ550	Φ550	Φ550	Φ550
	Max. turning diameter	mm	Φ480	Φ400	Φ400	Φ400
	Max. turning length	mm	520	480	450	450
	Bar hole	mm	Φ52	Φ52	Φ52	Φ52
Spindle	Spindle nose	-	A2-6	A2-6	A2-6	A2-6
	Spindle hole	mm	Φ65	Φ65	Φ65	Φ65
	Spindle speed	rpm	4200	4200	4200	4200
	Spindle motor	kw	11/15	11/15	11/15	11/15
	Chuck size	inch	8"	8"	8"	8"
Sub Spindle	Spindle nose	-	-	-	-	A2-5
	Spindle hole	mm	-	-	-	Φ56
	Spindle speed	rpm	-	-	-	5500
	Spindle motor	kw	-	-	-	17
	Chuck size	inch	-	-	-	6"
Axis travel	x/z/y axis travel	mm	260/610	260/480	260/580/±50	260/580/±50
	x/z/y axis motor	kw	3.0/3.0	3.0/3.0	3.0/3.0/1.4	3.0/3.0/1.4
	x/z/y axis rapid traverse	m/min	24/24	24/24	24/24/6	24/24/6
	positioning accuracy	mm	±0.005	±0.005	±0.005	±0.005
	repeat accuracy	mm	±0.003	±0.003	±0.003	±0.003
Tool Turret	Tool Turret type	-	12T	BMT55-12T	BMT55-12T	BMT55-12T
	O.D. tool holder	mm	25*25	25*25	25*25	25*25
	I.D. tool holder	mm	Φ40	Φ40	Φ40	Φ40
Tailstock	Tailstock type	-	Programmable hydraulic tailstock(Optional servo tailstock)			/
	Taper	-	MT#5	MT#5	MT#5	/
	Quill diameter	mm	Φ80	Φ80	Φ80	/
	Quill travel	mm	80	80	80	/
Machine dimensions	L*W*H	cm	2688*1739*1998	2688*1739*1998	2730*1739*2170	2730*1739*2170
	weight	kg	4000	4200	4300	4300