

**BF)Techno**

## **TZ-320 SERIES**



**BF Techno GmbH**  
**Munzer Technology**

# DIMENSIONS

## TZ SERIES

TZ-320 SERIES

## MODEL

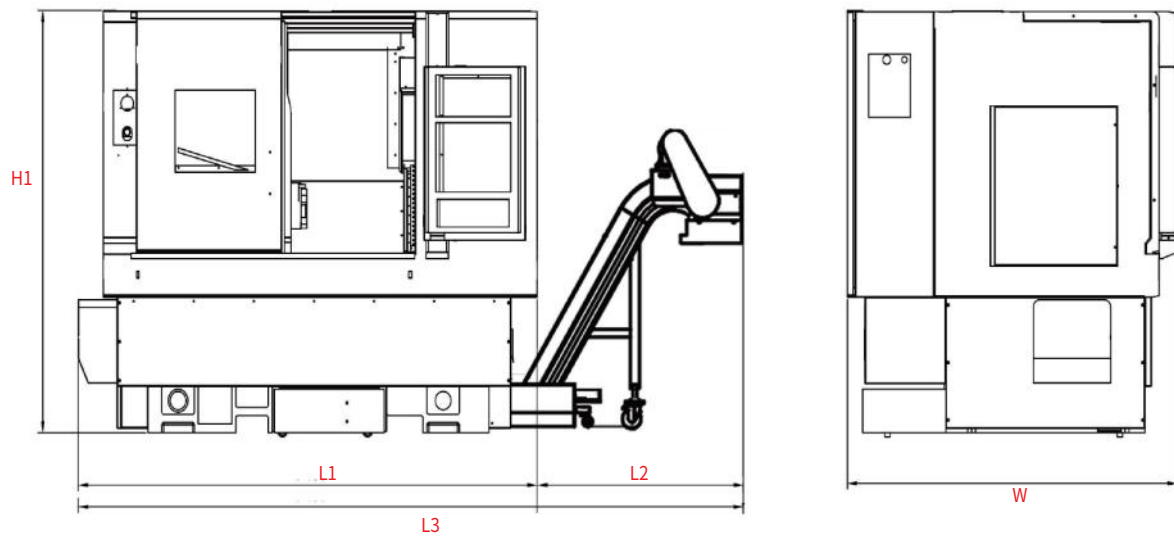

	TZ-320	TZ-320M	TZ-320Y
L1:	2330	2330	2330
L2:	1360	1360	1360
L3:	3690	3690	3690
W:	1675	1675	1675
H1:	1715	1715	1835



# TECHNICAL SPECIFICATIONS

## TZ SERIES

TZ-320 SERIES

CONTENT		unit	TZ-320	TZ-320M	TZ-320MY
Capacity	Max. swing over bed	mm	Φ460	Φ460	Φ460
	Max. turning diameter	mm	Φ360	Φ310	Φ310
	Max. turning length	mm	340	300	300
	Bar hole	mm	Φ45	Φ45	Φ45
Spindle	Spindle nose	-	A2-5	A2-5	A2-5
	Spindle hole	mm	56	56	56
	Spindle speed	rpm	4500	4500	4500
	Spindle motor	kw	7.5/11	7.5/11	7.5/11
	Chuck size	inch	6 "	6 "	6 "
Axis travel	x/z/y axis travel	mm	210/340	210/300	210/300/70
	x/z/y axis motor	kw	1.8/1.8	1.8/1.8	1.8/1.8/1.4
	x/z/y axis rapid traverse	m/min	24/24	24/24	24/24/6
	positioning accuracy	mm	±0.005	±0.005	±0.005
	repeat accuracy	mm	±0.003	±0.003	±0.003
Tool Turret	Tool Turret type	-	Servo Turret-12T	BMT45-12T	BMT45-12T
	O.D. tool holder	mm	25*25	25*25	25*25
	I.D. tool holder	mm	32	32	32
Tailstock	Tailstock type	-	Manual tailstock (hydraulic quill)		
	Taper		MT#4	MT#4	MT#4
	Quill diameter	mm	Φ60	Φ60	Φ60
	Quill travel	mm	80	80	80
Machine dimensions	L*W*H (include chip conveyor)	mm	3690*1675*1715	3690*1675*1715	3440*1675*1835
	w eight	kg	3000	3200	3300